

# Installation Instructions for the CL2255 Mortice Latch

## Contents

|   | CL2255 |
|---|--------|
| 1. Front plate                          | ✓      |
| 2. Back plate                           | ✓      |
| 3. Neoprene seals x 2                   | ✓      |
| 4. Spring loaded spindle                | ✓      |
| 5. Latch 60mm (2 3/8") backset          | ✓      |
| 6. Strike plate                         | ✓      |
| 7. Wood screws x 4                      | ✓      |
| 7. Use with latch & strike plate        | ✓      |
| 8. Latch support post                   | ✓      |
| 9. Spindle adaptor                      | ✓      |
| 10. Fixing bolts 3 supplied (spare x1)  | ✓      |
| 11. 2 keys                              | ✓      |
| 12. Cable Connections for REM1 and REM2 | ✓      |
| 13. 1.5v AA Batteries (x2)              | ✓      |

## Tools required for installation

- Power drill
- 25mm (1"), 20mm (13/16") & 8mm (5/16") drill bits
- Bradawl
- Philips screwdriver size 2
- Chisel - maximum 25mm (1")
- Hammer/Mallet
- Stanley knife
- Adhesive tape
- Pencil
- Tape measure

# Mortise Latchset

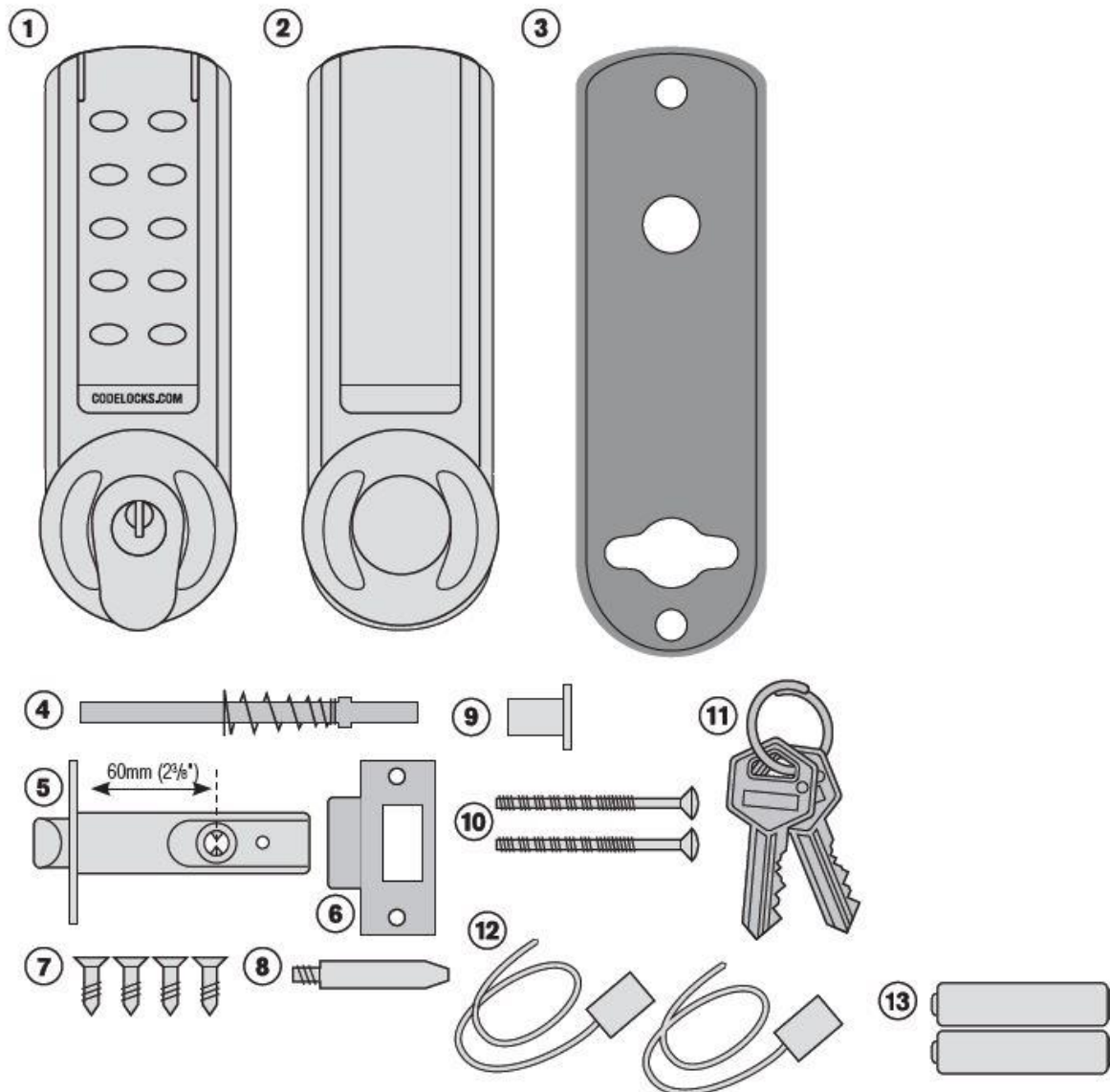

## Special Notes

You are advised to test lock (see below) and familiarise yourself with the instructions before starting work.

- Remove the battery cover from the back plate and install the 2 x AA cells supplied.
- Connect the cables from the front plate and back plate. A BLEEP should be heard when you do this. If no BLEEP is heard then check that the batteries are correctly installed.

- Enter the factory Master Code, 1234 (**note: when programming, the badge bar [CODELOCKS.COM](http://CODELOCKS.COM) must prefix the Master Code**). The blue LED will flash and the front knob can be turned using finger and thumb.
- Disconnect the cables.
- **Spindle adaptor** - The lock is supplied with a spindle adaptor (9) that can be used to work with tubular latches already installed that have an 8mm (5/16") square follower. To use adaptor slide onto the flat spindle (4) making sure the spindle is at the correct angle to suit the hand of your door - **See note 4. Positioning the spindle.**
- **Alternative latches** - Latches are available with 50mm (2") and 70mm (2 3/4") backsets on request.
- If required the hold open feature can be disabled as follows: Remove fixing plate by removing the four fixing screws and blue handling screw.
  1. Lift out the snib block.
  2. Flip over and reset. Refit the fixing plate. **Do not fit the blue handling screw.**

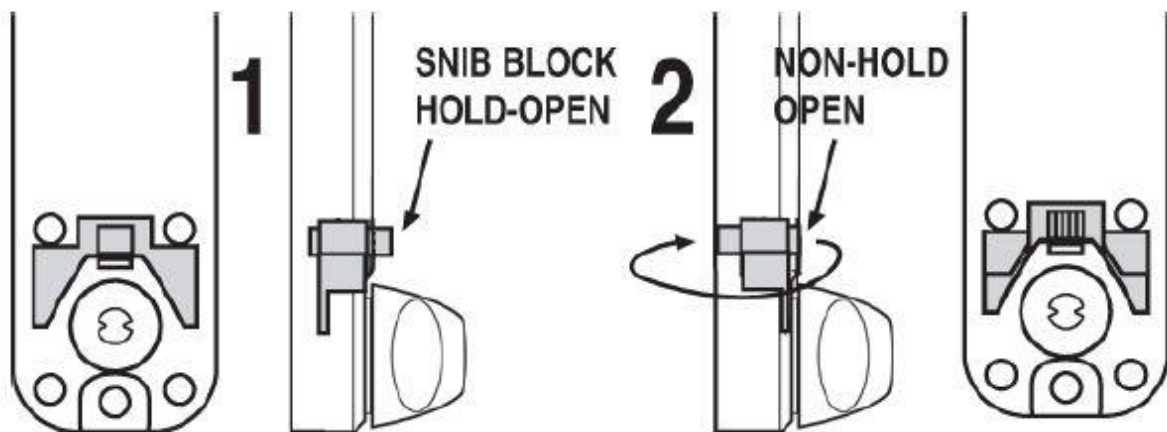

- When using the 'hold open' function please note that the backplate is fitted with a blue screw to stop the handle moving in the wrong direction. The screw should be in the left hand hole for a right hand door or the right hand hole for a left hand door.

## 1. Check the hand of your door

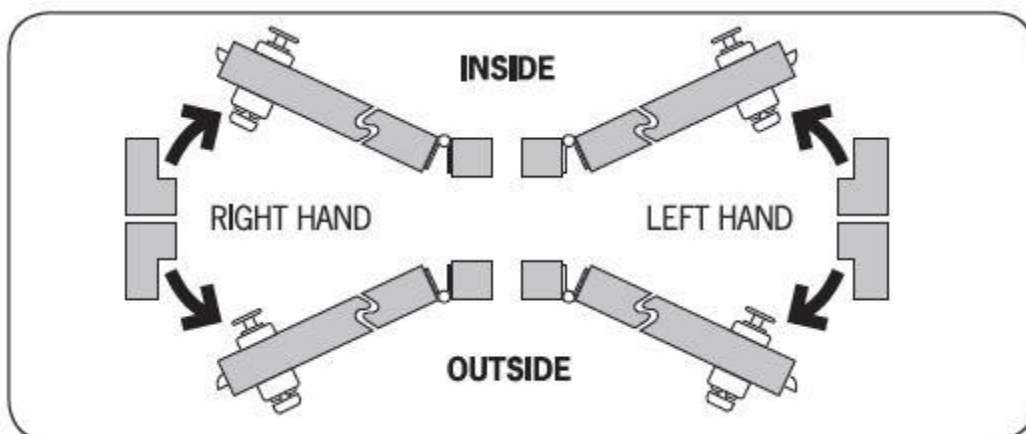

Viewed from outside, a door is right handed if the hinges are on the right, and left handed if the hinges are on the left.

## 2. Apply the template

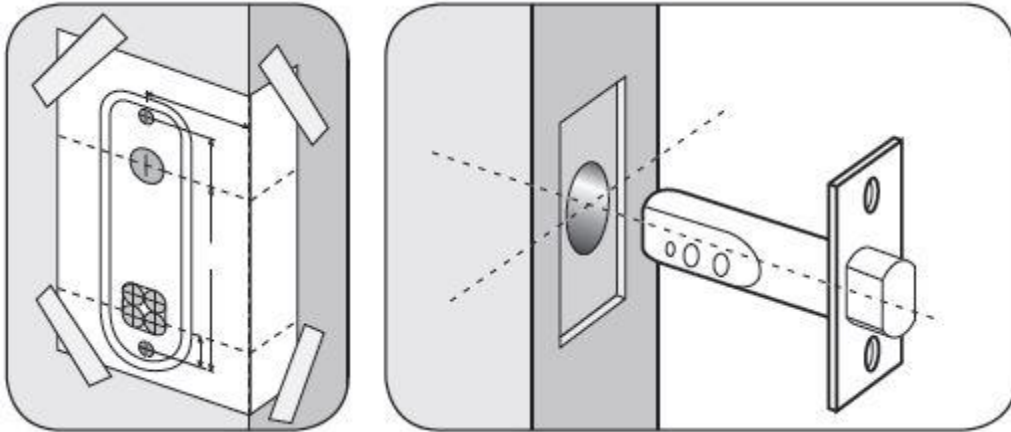

- Crease the template along the line marked Door Edge, and tape it to the door.
- Mark the 3 x 8mm (5/16") holes and the 2 x 20mm (13/16") holes. Mark the centre line of the latch in the middle of the door edge. Now apply the template to the other side of the door, aligning it with your first mark in the middle of the door edge. Mark the 5 holes again.
- Keeping the drill level and square to the door, drill holes from both sides to avoid splintering out of door face.

### **Positioning and fixing the latch**

- Mark a central point on the 'centre line of latch' on the door edge.
- Mark the depth of 85mm (3 3/8") on the drill bit with tape to act as a visible depth limit. Drill a 25mm (1") hole, 85mm (3 3/8") deep, keeping the drill level and square to the door.
- Insert the latch into the hole, and with the edges parallel to the door, draw around the face plate.
- Remove the latch. Score the pencil line with a Stanley Knife to avoid splitting prior to chiselling. Chisel a 3mm (1/8") rebate to fit the latch face flush to the door edge.
- Fix the latch with the wood screws, with the bevel towards the door frame.

### 3. Latch support post

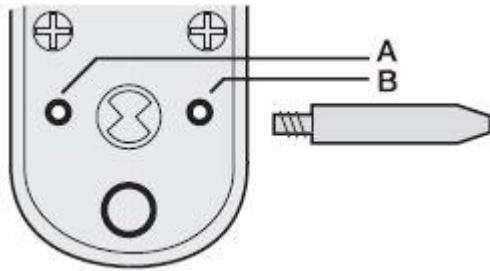

- Fit the Latch Support Post in the back of the lockcase, in hole A for a Right Hand door, or B for a Left Hand door.

### 4. Positioning the Spindle

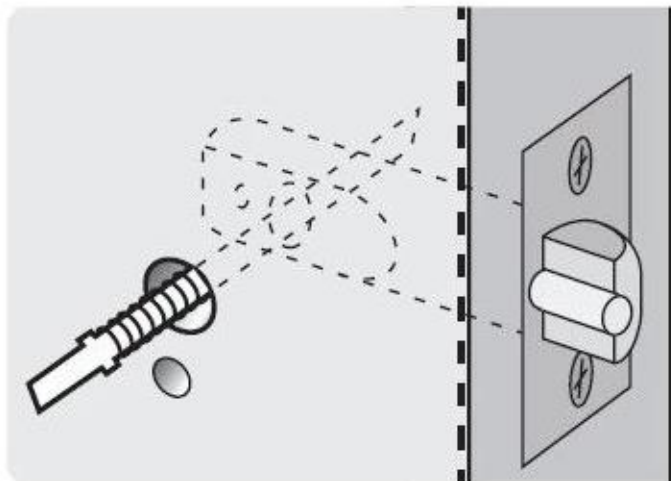

**Viewed from the outside**

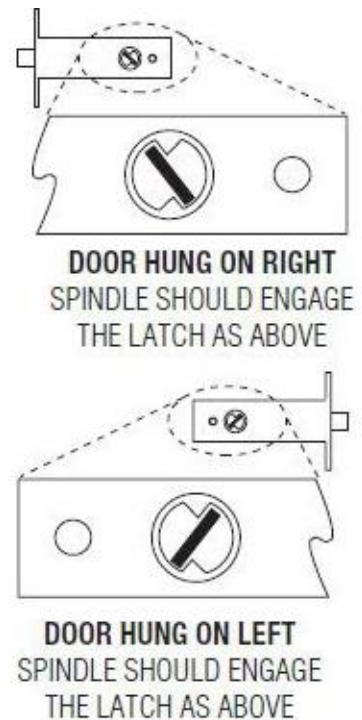

**DOOR HUNG ON RIGHT**  
SPINDLE SHOULD ENGAGE  
THE LATCH AS ABOVE

**DOOR HUNG ON LEFT**  
SPINDLE SHOULD ENGAGE  
THE LATCH AS ABOVE

- The spring-loaded spindle will fit doors between 35mm and 65mm (1 3/8" - 2 1/2") thick. For doors less than 50mm (2") thick break of the 15mm (5/8") section at the end of the spindle. For doors more than 65mm (2 1/2") thick, ring the Helpline for advice. The spring keeps the spindle firmly engaged in the outside handle when the lock is assembled on the door.
- Insert the spindle, with the spring on the code side, through the 20mm (1 3/16") hole in the door, and make sure that it engages the latch correctly for the hand of the door (see inset diagram).

## 5. Fixing the lock

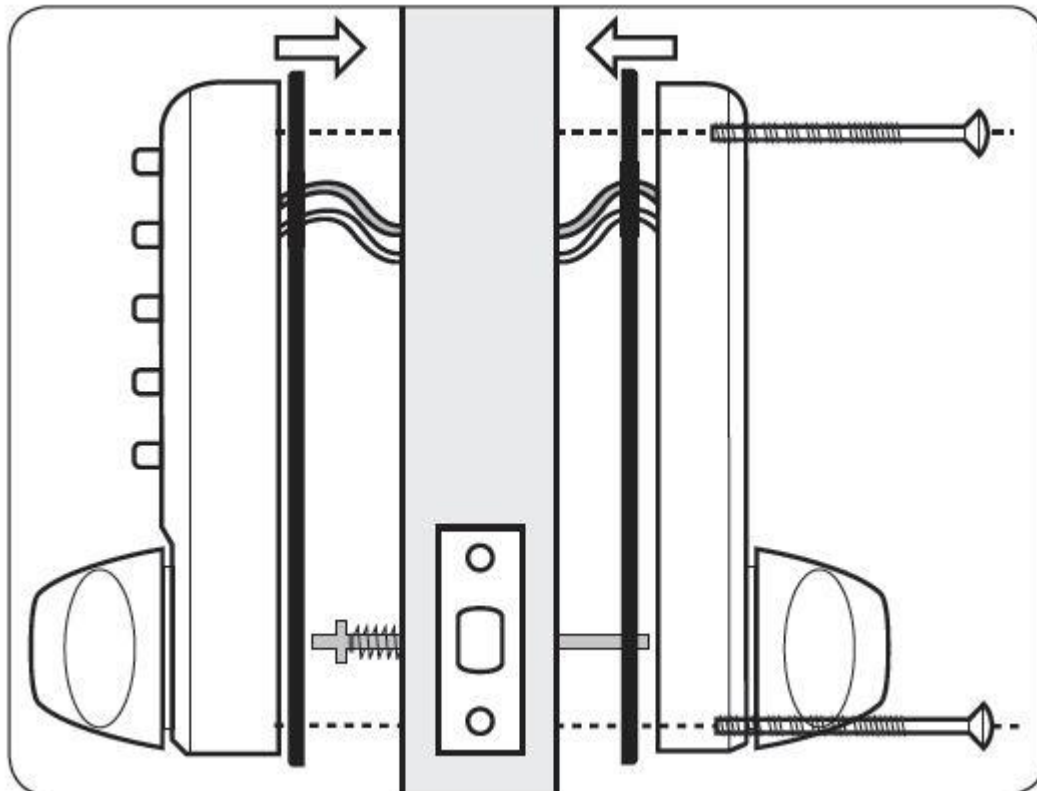

- Cut the fixing bolts to suit the door thickness, length of bolts measured beneath the bolt head should be door thickness **plus** 15mm (5/8"). Use the pliers cutting jaws to crimp strongly several times around the bolt. The surplus end should now break off easily.
  - Remove the battery cover from the back plate, and remove the battery pack. Apply the front plate over the spindle, passing the latch support post through the latch and the cable through the door. Place the back plate over the spindle, pull the cable through, and screw the fixing bolts through to the front plate.
  - Using the inside knob check that the spindle moves freely, and that the latch retracts and projects smoothly. If it is tight, loosen the fixing bolts slightly and adjust the position of the back plate until the spindle will turn freely. Tighten the fixing bolts. Test the spindle again. **DO NOT** over-tighten the bolts as this may cause the door to distort and affect the lock function.
- DO NOT CLOSE THE DOOR UNTIL YOU ARE SURE THAT THE CODE WORKS - FOLLOW BELOW POINT TO CHECK.**
- Connect the cables, storing any excess within the door, then install the battery pack. Enter the Master Code, the blue light will flash and the outside knob will retract the latch.

## 6. Fitting the strike plate

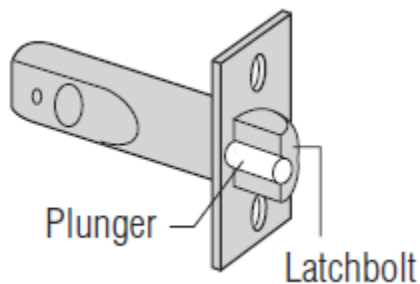
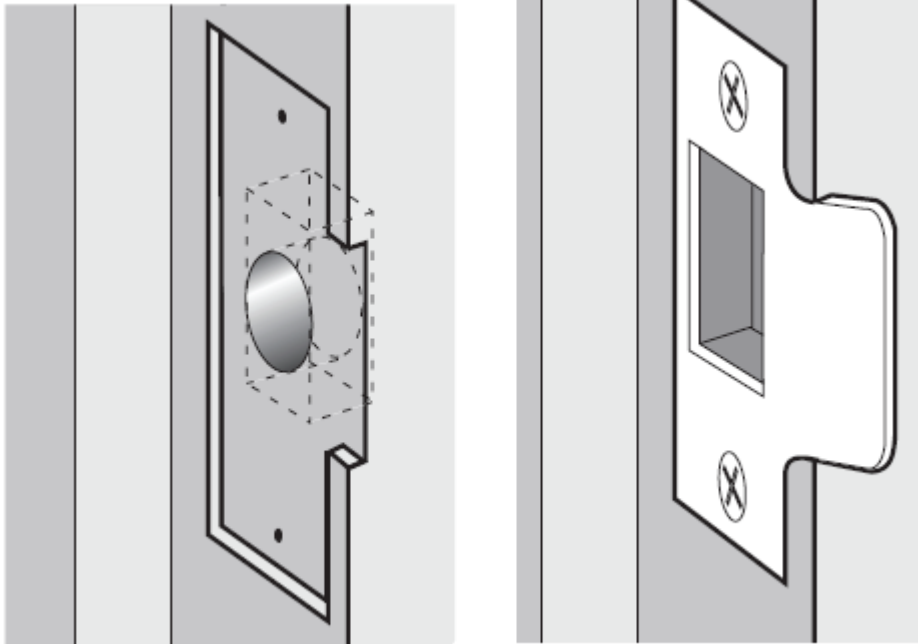

**NB** The plunger beside the latchbolt deadlocks the latchbolt and protects it against manipulation. IT MUST NOT enter the strike plate aperture when the door is closed.

- Ensure that there are no obstructions to prevent the door closing properly into its frame, such as litter trapped in the hinge side.
- Position the strike plate on the door frame so that it lines up with the flat of the latchbolt, NOT THE PLUNGER.
- Draw around the aperture of the strike plate. Chisel out the aperture 15mm (5/8") deep to receive the latchbolt. Fix the strike plate to the surface of the frame with one screw only. Close the door and ensure that the latch bolt enters the aperture easily, and is held without too much 'play'. When satisfied, draw around the final position of the strike plate, remove it and cut a 1mm (1/16") rebate to enable it to fit flush. Re-fix the strike plate with both screws.